

**KUNKLE SAFETY AND RELIEF PRODUCTS**

MODELS 189, 363 AND 389

ASME Section VIII, Air/Gas Cryogenic, "UV" National Board Certified, Safety Valves

**Model 189**
**Model descriptions**

**Model 189:** Bronze housing with Stainless Steel (SS) trim (nozzle and disc) with Teflon® seat/seal in disc. Plain lift lever.

**Model 189C:** Same as model 189 except pressure tight cap for gas service only. Suitable for maximum back pressure of 50 psig.<sup>1</sup>

**Model 189P:** Same as model 189 except pressure tight packed lift lever. Suitable for maximum back pressure of 50 psig.<sup>1</sup>

**Model 363:** Bronze housing with SS trim (nozzle and disc) with Teflon® seat/seal in disc. Plain lift lever. 1000 psig maximum set pressure.

**Model 363C:** Same as model 363 except pressure tight cap for gas service only. Suitable for maximum back pressure of 50 psig.<sup>1</sup> 1000 psig maximum set pressure.

**Model 363P:** Same as model 363 except pressure tight packed lift lever. Suitable for maximum back pressure of 50 psig.<sup>1</sup> 1000 psig maximum set pressure.

**Model 389C:** All SS with Teflon® seat/seal in disc. Pressure tight cap for gas service only. Suitable for maximum back pressure of 50 psig.<sup>1</sup>

**Model 389P:** Same as model 389C except pressure tight packed lift lever. Suitable for maximum back pressure of 50 psig.

**Technical data**
**Pressure and Temperature Limits**
**Model 363:**

 50 to 1000 psig  
 -320° to 350°F

**Model 189:**

 1000 to 2500 psig  
 -320° to 350°F

**Model 389:**

 50 to 2500 psig  
 -320° to 350°F

Code:

**Note:**

1. Back pressure increases set pressure on a one to one basis, and reduces capacity. Back pressure in excess of 10% of set pressure is not recommended.

**Applications**

- Cryogenic "cold" and liquefied air, oxygen and gas service.
- Multi-stage air and gas compressors, intercoolers, aftercoolers and receivers.
- Thermal expansion relief and/or full rated capacity discharge.
- Air, gas and liquefied gas lines and systems.

# KUNKLE SAFETY AND RELIEF PRODUCTS

MODELS 189, 363 AND 389

## Parts and Materials

### Models 189C, 363C and 389C

No.	Part Name	189C and 363C	389C
1	Nozzle	SS SA479-316	SS SA479-316
2	Body Lock Screw	Brass B16	SS Commercial
3	Body Gasket	Teflon®	Teflon®
4	Lock Screw Gasket	Teflon®	Teflon®
5	Lock Screw-Ring	Brass B16	SS A582-303
6	Spring Pin <sup>1</sup>	SS Commercial	SS Commercial
7	Body	Bronze SB-62	SS SA351-CF8M
8	Spring	SS A313-304	SS A313-304
9	Stem	SS A582-303	SS A582-303
10	Top Spring Step	SS A582-303	SS A582-303
11	Jam Nut	Brass B16	SS A582-303
12	Compression Screw	SS A582-303	SS A582-303
13	Cap	Brass B16	SS SA479-316
14	Cap Gasket	Teflon®	Teflon®
15	Retainer Nut	SS 582-303	SS A582-303
16	Bottom Spring Step	SS A582-303	SS A582-303
17	Disc	SS A582-303	SS A582-303
18	Regulator Ring	Brass B16	SS A743-CF8M
19	Seat	Teflon®	Teflon®
20	Guide	SS A582-303	SS A582-303

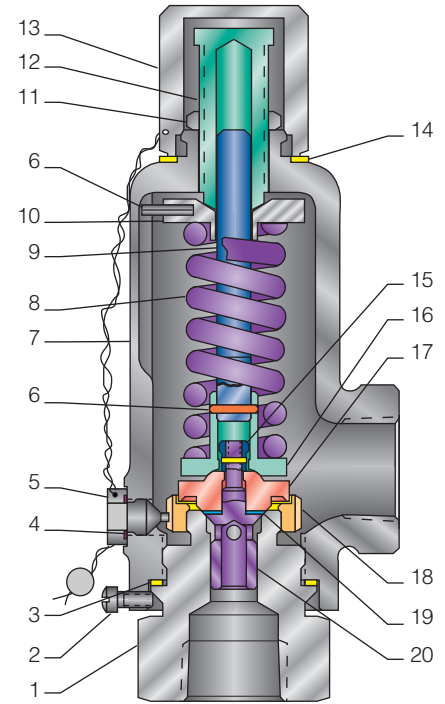

Threaded Cap

### Models 189P, 363P and 389P With Packed Lift Lever

No.	Part Name	189P, 363P	389P
9	Spring Pin	SS Commercial	SS Commercial
10	Body	Bronze SB-62	SS SA351-CF8M
11	Spring	SS A313-304	SS A313-304
12	Stem	SS A582-303	SS A582-303
13	Spring Step - Top	SS A582-303	SS A582-303
14	Jam Nut	Brass B16	SS A582-303
15	Compression Screw	SS A582-303	SS A582-303
16	Cap	Bronze B584 Alloy 84400	SS A743-CF8M
17	Lift Cam	SS A473-CF8M	SS A743-CF8M
18	Cotter Pin	Steel Commercial	Steel Commercial
19	Lever	Steel A108, Zinc Plated	Steel A108, Zinc Plated
20	Drive Screw	SS Commercial	SS Commercial
21	Retainer Nut	Brass B16	SS A479-316
22	O-ring	BUNA-N	BUNA-N
23	Lift Nut	Steel A108, Zinc Plated	Steel A108, Zinc Plated

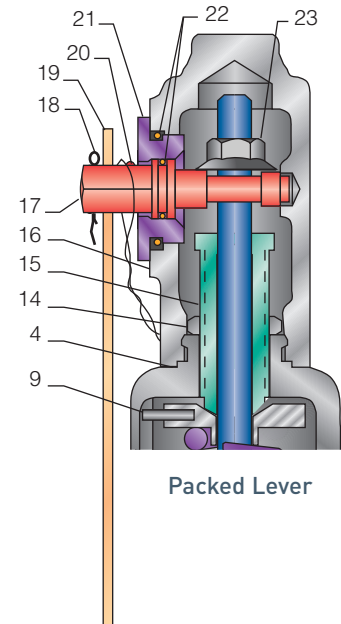

Packed Lever

#### Note:

1. Upper spring pin available on Models 189C and 389C.

**Parts and Materials**

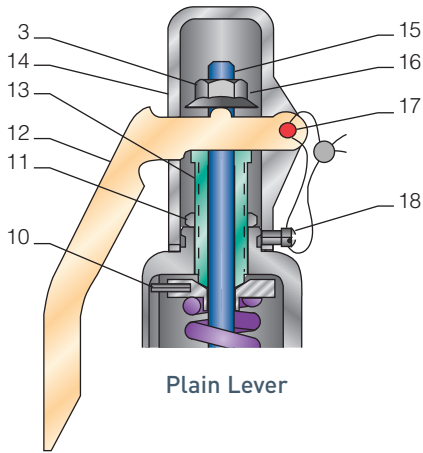

Models 189 and 363 With Plain Lever		
No.	Part Name	189, 363
10	Spring Pin <sup>1</sup>	SS Commercial
11	Jam Nut	Brass B16
12	Lever	Steel A109, Zinc Plated
13	Compression Screw	Brass B16
14	Cap	Aluminum, SB85 A380.0
15	Stem	SS A582-303
16	Lift Nut	Steel A108, Zinc Plated
17	Rivet	Steel Commercial
18	Lock Screw	SS Commercial

**Note:**

1. Spring pin available on Models 189 and 389 only.

Specifications							
Size Inlet	Outlet	Dimensions, in					Weight (lb)
		A	B	C Cap	C Plain Lever	C Packed Lever "P"	
1/2" or 3/4"	3/4"	27/16	1 3/4	7 3/16	9	8 1/2	5

Dimensions are for reference only.

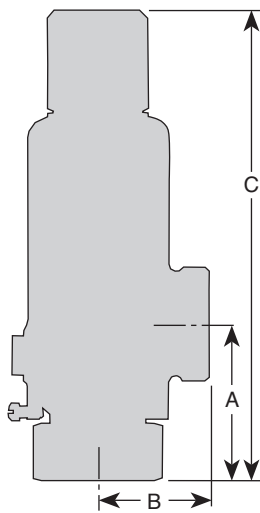

Models 189 and 363

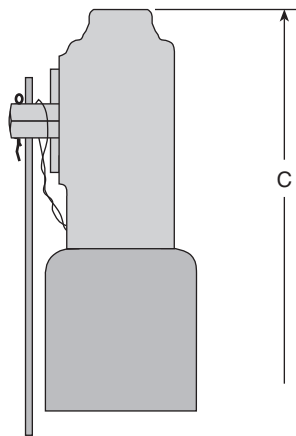

Models 189P, 363 and 389P  
(packed lift lever)

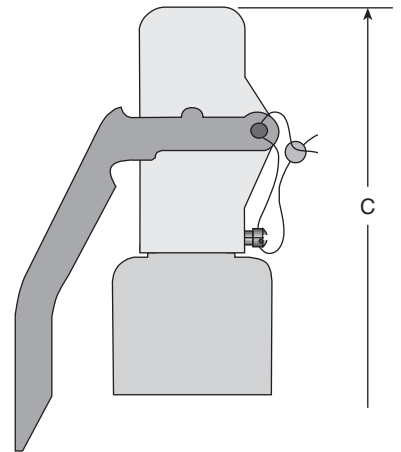

Models 189 and 363  
(plain lever)

# KUNKLE SAFETY AND RELIEF PRODUCTS

MODELS 189, 363 AND 389

## Model Number/Order Guide

Model Number Position	1	2	3	4	5	6	7	8	9	10	11	12	13	14	15	
<b>Example</b>	0	1	8	9	—	D	0	1	—	K	H	0	1	0	0	
<b>Model</b>	0189		189C		189P		0363		363C		363P		389C		389P	
<b>Inlet Size</b>	C - 1/2"				D - 3/4"											
<b>Variation</b>	01 - Catalog Standard															
	02 - Plain Lever with Vibration Dampener (Model 0189 and 0363 only)															
	02 - Packed Lever with Gag (Model 189P only)															
<b>Design Revision</b>	Indicates non-interchangeable revision. Dash (-) if original design.															
<b>Service</b>	K - Air ASME Section VIII															
	N - Non-code Air (Models 0363, 363C, 363P, 389C, 389P only)															
<b>Spring Material</b>	H - 304 SS															
<b>Set Pressure</b>	Model 189 - 1000 psig (1000) to 2500 psig (2500)															
	Model 363 - 50 psig (0050) to 1000 psig (1000)															
	Model 389 - 50 psig (0050) to 2500 psig (2500)															

## Capacities for ASME Section VIII Air, (SCFM)

Set Pressure (psig)	Capacity (SCFM)
50	38
100	68
150	98
200	128
250	158
300	188
350	218
400	248
450	278
500	308
550	338
600	368
650	397
700	427
750	457
800	487
850	517
900	547
950	577
1000	607
1050	637
1100	667
1150	697
1200	727
1250	757
1300	787
1350	817
1400	847
1450	877
1500	907
1550	937
1600	967
1650	997
1700	1027
1750	1057
1800	1087
1850	1117
1900	1146
1950	1176
2000	1206
2050	1236
2100	1266
2150	1296
2200	1326
2250	1356
2300	1386
2350	1416
2400	1446
2450	1476
2500	1506



VALVES & CONTROLS

5500 WAYZATA BLVD # 800, MINNEAPOLIS, MN 55416 WWW.PENTAIR.COM/VALVES

KUNKLE FACILITY PHONE: 1-828-669-3700 • WWW.KUNKLEVALVE.COM

All Pentair trademarks and logos are owned by Pentair, Ltd. All other brand or product names trademarks or registered marks of their respective owners.

Because we are continuously improving our products and services, Pentair reserves the right to change specifications without prior notice. Pentair is an equal opportunity employer.